

Parts Diagram

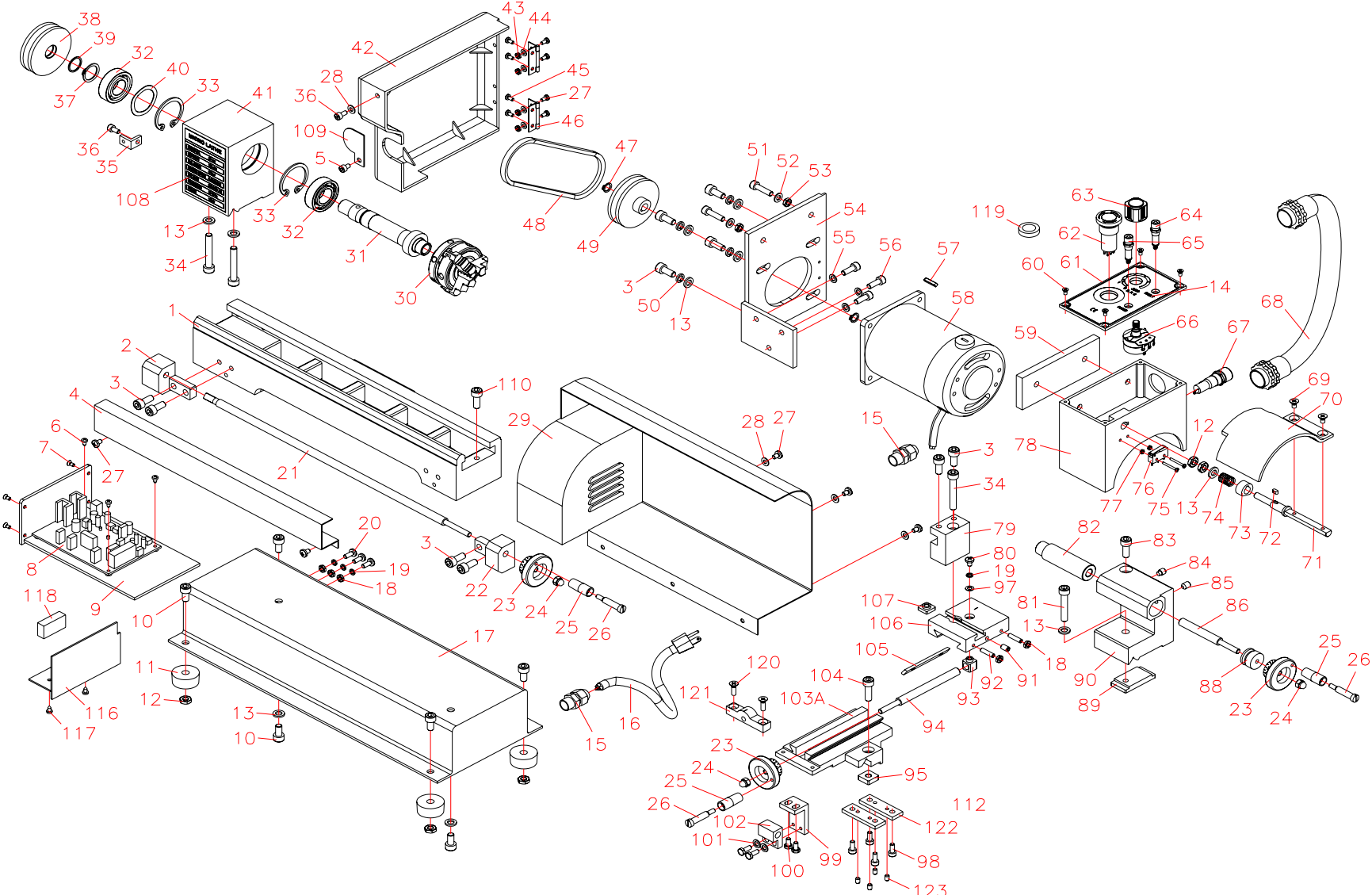

Parts List (I)

Item	Part name	Qty.	Item	Part name	Qty.
1	Bed way	1	51	Screw M5*20	2
2	Leadscrew left support	1	52	Small washer 5	2
3	Screw M6*14	10	53	Nut M5	2
4	Protective cover for leadscrew	1	54	Motor connect plate	1
5	Screw M4*6	1	55	Washer 5	3
6	Screw ST2.9*6.5	3	56	Screw M5*14	3
7	Screw M3*8	4	57	key 3*16	1
8	PC Board	1	58	DC Motor	1
9	Electricity fixed plate	1		Mat plate	1
10	Screw M6*12	6	60	Screw ST2.9*9.5	4
11	Rubber pad	4	61	Electric box cover	1
12	Nut M6	6	62	Emergency stop button	1
13	Small washer 6	10	63	Variable speed control knob	1
14	Switch label	1	64	Yellow lamp	1
15	lock connect	2	65	Green lamp	1
16	Power line	1	66	Variable speed control	1
17	Base	1	67	Fuse box	1
18	Nut M4	5	68	plastic tube	1
19	Spring washer 4	7	69	Screw M4*8	2
20	Screw M4*10	3	70	protective cover for chuck	1
21	leadscrew	1	71	Rotate shaft	1
22	Leadscrew right support	1	72	key 3*6	1
23	Handle wheel	3	73	Spacer	1
24	Cap nut M5	3	74	Compress spring L=16	1
25	Rotate small handle	3	75	Screw M2*20	2
26	Handle screw	3	76	Micro switch	1
27	Screw M4*6	9	77	Nut M2	2
28	Flat washer 4	4	78	Electric box	1
29	Dust guard	1	79	Knife rest	1
30	3 jaw chuck	1	80	Screw M4*6	1
31	Spindle	1	81	Screw M6*35	1
32	Bearing 17*35*10	2	82	Tailstock shaft	1
33	check ring 35	2	83	Screw M6*16	1
34	Screw M6*40	3	84	Set screw	1
35	Fixed support	1	85	Set screw M6*8	1
36	Screw M4*8	2	86	Tailstock shaft leadscrew	1
37	Check ring 17	1	87	Small handle	2
38	V pulley	1	88	Nesting	1
39	Adjust ring	1	89	baffle	1
40	Washer	1	90	Tailstock	1
41	Headstock	1	91	Screw M5*8	1
42	Pulley cover	1	92	Screw M4*16	2
43	Nut M4	4	93	Saddle nut	1
44	Washer 4	4	94	Leadscrew	1
45	Screw M4*8	6	95	Saddle nut	1
46	Higne 38*31	2	97	Small washer 4	4
47	Check ring 8	2	98	Screw M4*10	4
48	V belt	1	99	Nut support	1
49	V pulley	1	100	Bolt M4*10	4
50	Spring washer 6	4	101	Washer 4	2

Parts List (II)

Item	Part name	Qty.	Item	Part name	Qty.
102	Leadscrew nut	1	116	Baffle	1
103A	Saddle	1	117	Screw ST 2.9*6.5	2
104	Screw M6*20	1	118	Filter	1
105	Saddle wedge	1	119	Porcelain	1
106	middle saddle	1	120	Cap screw M4*14	2
107	Rest nut	1	121	Support	1
108	Main label	1	122	Press plate	2
109	baffle	1	123	Set screw M4*6	4
110	Screw M5*10	1			

Packing List

No.	Descriptions	Q'ty	Remarks
1	Micro Lathe	1	
2	L Hex. Wrench S:3, 4, 5	Each 1	
3	Double end wrench 5.5*7	1	
4	Fuse	1	
5	Screw Driver	1	
6	Instruction Manual	1	